

CODE	ADAPTER						DRIVE DISK						REMARKS
	SAE	XD	XB	XC	H	J	SAE	K	M	XE	XF	XG	
A	#3	409.6 [16.13]	428.6 [16.87]	451 [17.8]	12	10.8 [.43]	#11 1/2	8	9.53 [.375]	352.4 [13.87]	333.3 [13.12]	39.6 [1.56]	
Y	#4	361.9 [14.25]	381.0 [15.00]	405 [15.9]	12	10.8 [.43]	#10	8	9.53 [.375]	314.3 [12.37]	295.2 [11.62]	54.0 [2.13]	
Q	#5	314.0 [12.36]	333.4 [13.13]	359 [14.1]	8	10.8 [.43]	#7 1/2	8	7.95 [.313]	241.3 [9.50]	222.3 [8.75]	30.2 [1.19]	
I	#5	314.3 [12.38]	333.2 [13.12]	356 [14.0]	8	10.4 [.41]	#6 1/2	6	8.64 [.340]	215.9 [8.50]	200.2 [7.88]	30.2 [1.19]	10/9/2009
R	#5	314.3 [12.38]	333.2 [13.12]	356 [14.0]	8	10.4 [.41]	#8	6	10.41 [.410]	263.5 [10.37]	244.3 [9.62]	62.0 [2.44]	10/9/2009
V	#4	362.0 [14.25]	381.0 [15.00]	403 [15.9]	12	10.4 [.41]	#6 1/2	6	8.64 [.340]	215.9 [8.50]	200.2 [7.88]	30.2 [1.19]	10/9/2009
G	#4	362.0 [14.25]	381.0 [15.00]	403 [15.9]	12	10.4 [.41]	#7 1/2	8	8.64 [.340]	241.3 [9.50]	222.3 [8.75]	30.2 [1.19]	10/9/2009
C	#4	362.0 [14.25]	381.0 [15.00]	403 [15.9]	12	10.4 [.41]	#8	6	10.41 [.410]	263.5 [10.37]	244.3 [9.62]	62.0 [2.44]	10/9/2009
X	#3	409.6 [16.13]	428.8 [16.88]	451 [17.8]	12	10.7 [.42]	#8	6	10.41 [.410]	263.5 [10.37]	244.3 [9.62]	62.0 [2.44]	10/9/2009
D	#3	409.6 [16.13]	428.8 [16.88]	451 [17.8]	12	10.7 [.42]	10	8	10.41 [.410]	314.3 [12.37]	295.1 [11.62]	53.8 [2.13]	10/9/2009

771187-0A

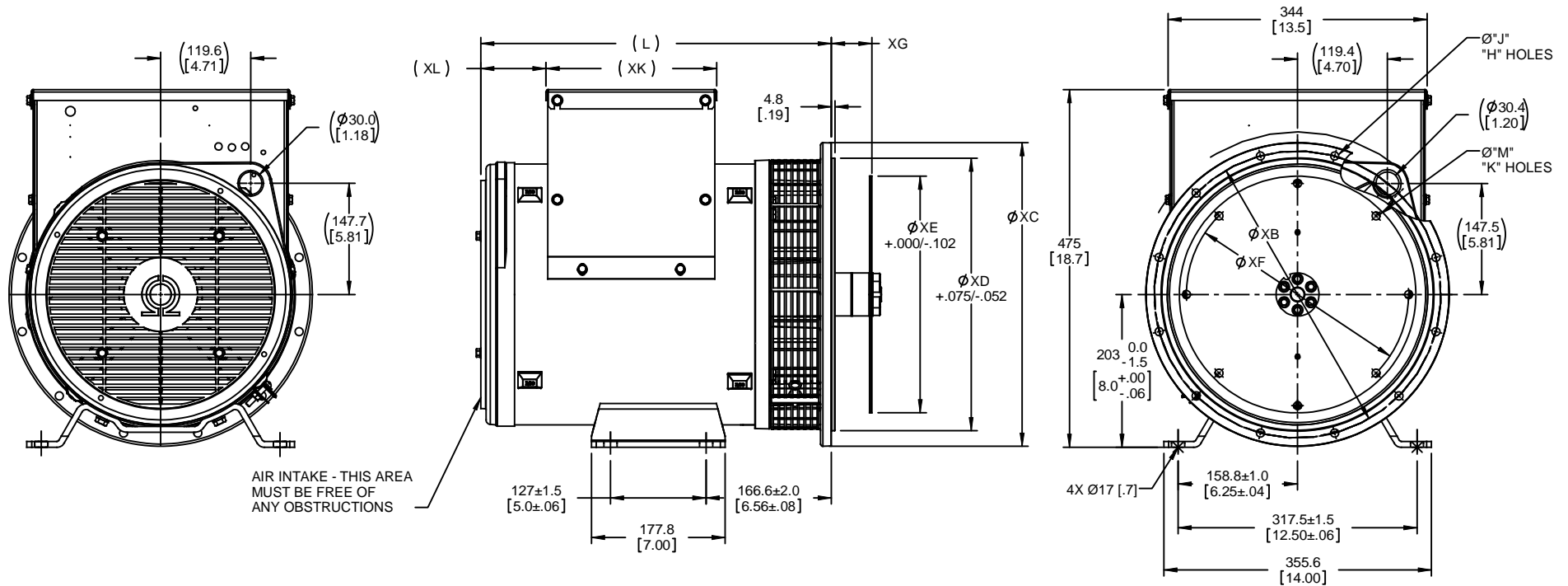

DIMENSIONS IN [] ARE IN INCHES

FRAME	L	XL	XK
281	415 [16.3]	88.9 [3.50]	174.2 [6.86]
282	466 [18.4]	86.6 [3.41]	226.8 [8.93]
283	529 [20.8]	86.6 [3.41]	226.8 [8.93]
284	580 [22.8]	86.6 [3.41]	226.8 [8.93]

TOLERANCES UNLESS SPECIFIED		MARATHON ELECTRIC		DRAWN MRB 9/30/2008	
DEC	METRIC	CHK	ANG	FINISH	APPR LS 09/30/2008
x	±2.5	xx	±.76	TITLE OUTLINE	SCALE 3:16
xxx	±.127	xxx	±.127	281-284 FR. CSL GEN -1 BRG	REF 771800-0A
1	ADDED LIFT LUG LOCATIONS	MRB 12/3/2009	LS xxx	MATL	FMF
NO	REVISION	BY & DATE	CHK ANG ±730°	FINISH	PREV
THIS DRAWING IN DESIGN AND DETAIL IS OUR PROPERTY AND MUST NOT BE USED EXCEPT IN CONNECTION WITH OUR WORK. ALL RIGHTS OF DESIGN AND INVENTION ARE RESERVED. THIS IS AN ELECTRONICALLY GENERATED DOCUMENT - DO NOT SCALE THIS PRINT				RFP 9/30/2008	CAD FILE 771187-0a
				SIZE B	DRAWING NO 771187-0A
				DIST LM	REV 1