



Fußausführung / Foot Design

Bauform / mounting IMB3

Motor mit Schutzdach

motor with canopy

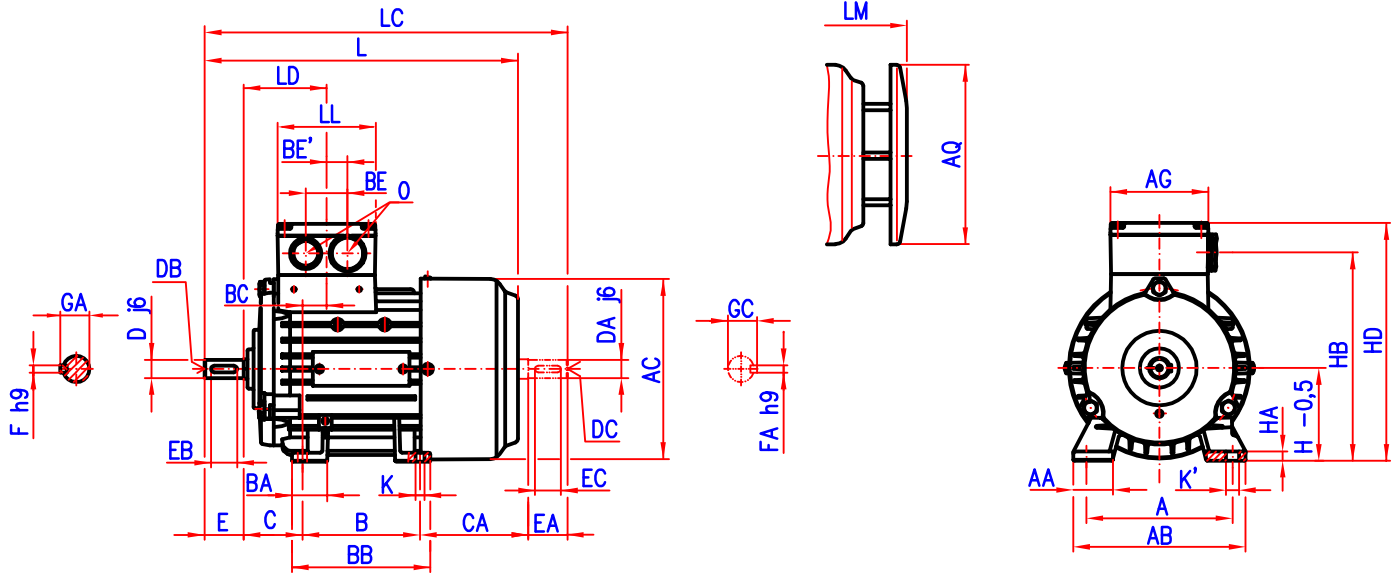

Flanschausführung / Flange Design

Bauform / mounting IMB5; IMB35

IMB14; IMB34

Z= Anzahl der Befestigungslöcher

Z= No. of fixing holes

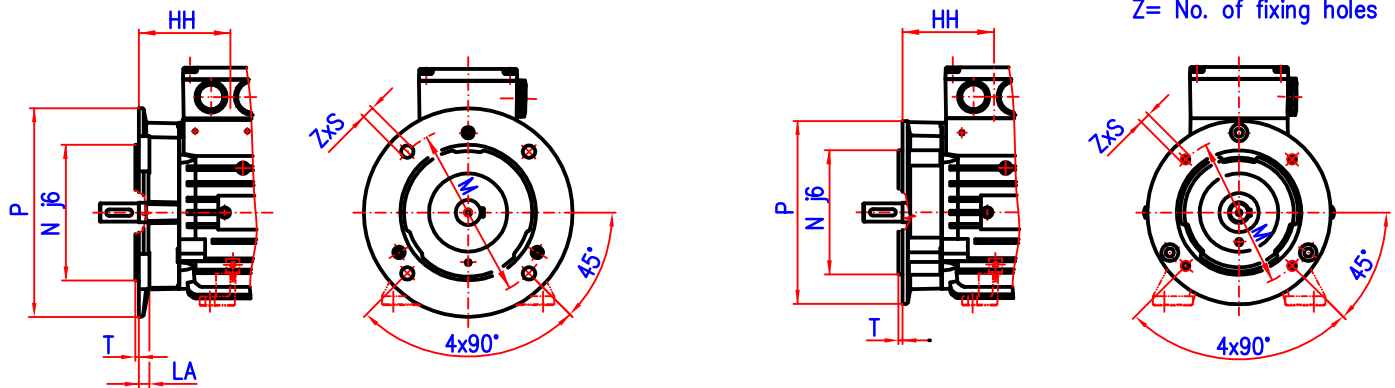

Kabeleinführung drehbar um 90° / Cable gland can be turned round 90 deg.

TYP	Bauform / mounting IMB3; IMB5; IMB35; IMB14; IMB34																									
	IEC	A	AA	AB	AC	AQ	B	BA	BB	BC	BE	BE'	C	CA	H	HA	HB	HD	HH=LD	K	K'	L	LC	LL=AG	LM	O
DIN	b	n	f	g	j	a	m	e	x3	x	x2	w1	w2	h	c	v	p	x5=x	s	s1	k	k1	x1=r	k2	s3	
5AP63	100	27	120	124	124	80	28	96	30	32	18	40	66	63	7	140,5	164	69,5	7	10	202,5	232	75	231		
5AP63V													92												268	M16x1,5 M25x1,5

TYP	Wellenende / shaftend												Bauform / mounting															
	A Seite / A side						B Seite / B side						IMB5				IMB14A				IMB14B							
IEC	D	DB	E	EB	F	GA	DA	DC	EA	EC	FA	GC	LA	M	N	P	ZxS	T	M	N	P	ZxS	T	M	N	P	ZxS	T
DIN	d	d6	l	-	u	t	d1	d7	l1	-	u1	t1	c1	e1	b1	a1	s2	f1	e1	b1	a1	s2	f1	e1	b1	a1	s2	f1
5AP63	11	M4	23	16	4	12,5	11	M4	23	16	4	12,5	8	115	95	140	4x10	3	75	60	90	4xM5	2,5	100	80	120	4xM6	3

• Alle Maße in mm. • All measures in mm.