

SINGLE STAGE VOLUTE CASING PUMPS

DIN EN 22858 / ISO 2858 / ISO 5199
AND ADDITIONAL SIZES

KRC

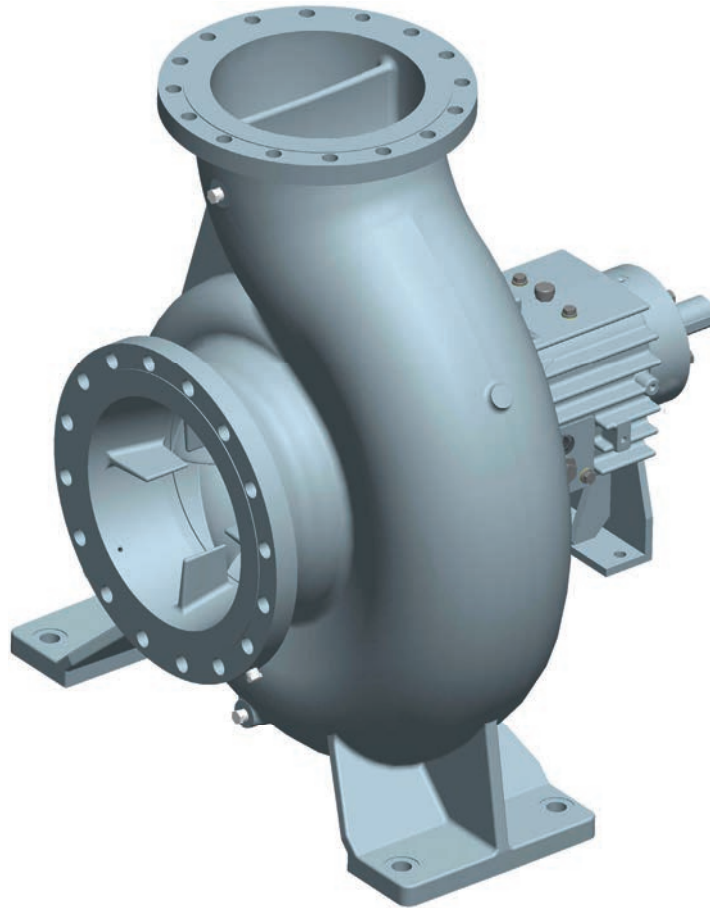

- Additional sizes up to nominal size 350 – with a heavy-duty process bearing housing
- Large variety of material versions available
- Versatile shaft sealing options
- DIN EN and ASME flange dimensions
- Low NPSH values

APOLO
Pumps
Pumping Systems

Range of Applications

Chemical standard pumps and additional sizes of optimum performance range for universal and demanding applications, such as:

- energy technology
- chemical plants
- oil and gas industry
- building technology
- power plants
- general industry

Design

- single-stage, single-flow, volute casing pump of normal suction in dimensions according to DIN EN 22858
- extensive capacity range due to expansion sizes available
- horizontal design with oil-lubricated bearings
- KRCB – block design with flange motor
- KRCV – vertical suspended version
- type KRCO with solid bearing housing and open impeller
- optionally: improvement of NPSH value by version with Inducer
- flanges according to DIN EN or ASME

Shaft Seal

The seal chamber allows the installation of standard mechanical seals according to DIN EN 12756 as single mechanical seals. Double sealing systems, cartridge mechanical seals as well as special seals are available. The material versions of the mechanical seals are adapted to operating parameters and to the liquid.

Designation

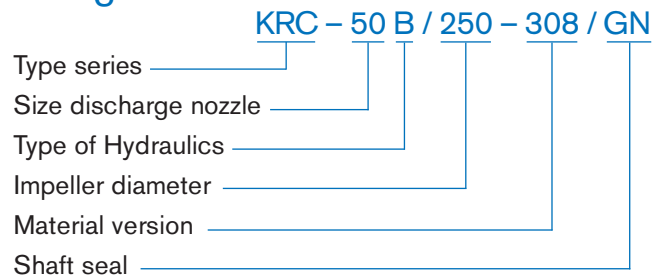

Operating Data

Nozzle size (mm)	from 25 to 350
Capacity	up to 3000 m ³ /h
Head	up to 160 m
Pressure design	up to 16/25 bar
Operating temperature	up to 180 °C

Materials

APOLLO-Code	000	005	100	108	308	508
Volute Casing	0.6025	0.6025	0.7040	0.7040	1.0619	1.4408
Casing cover	0.6025	0.6025	0.7040	0.7040	1.0619	1.4408
Shaft	1.4057	1.4057	1.4057	1.4057	1.4057	1.4571
Bearing housing	0.6025	0.6025	0.6025	0.6025	0.6025	0.6025
Impeller	0.6025	2.1096.01	0.6025	1.4317	1.4317	1.4408

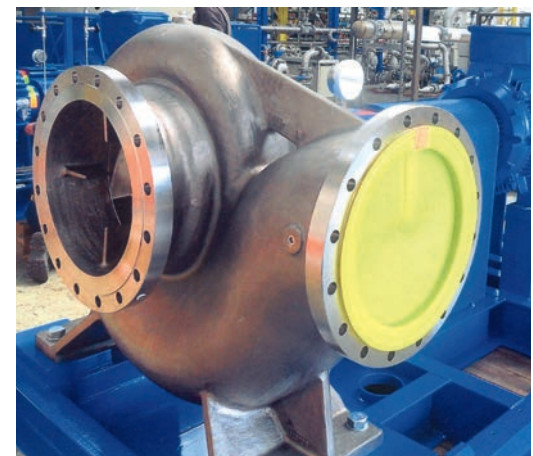
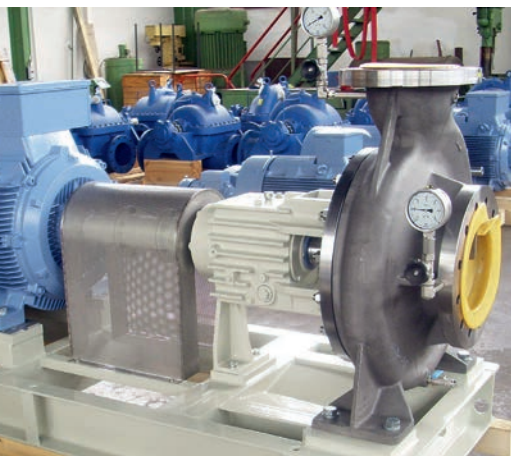

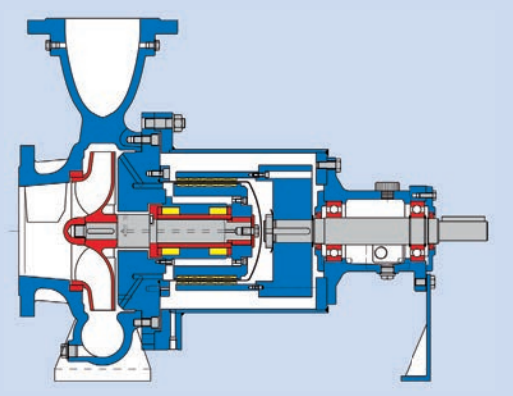
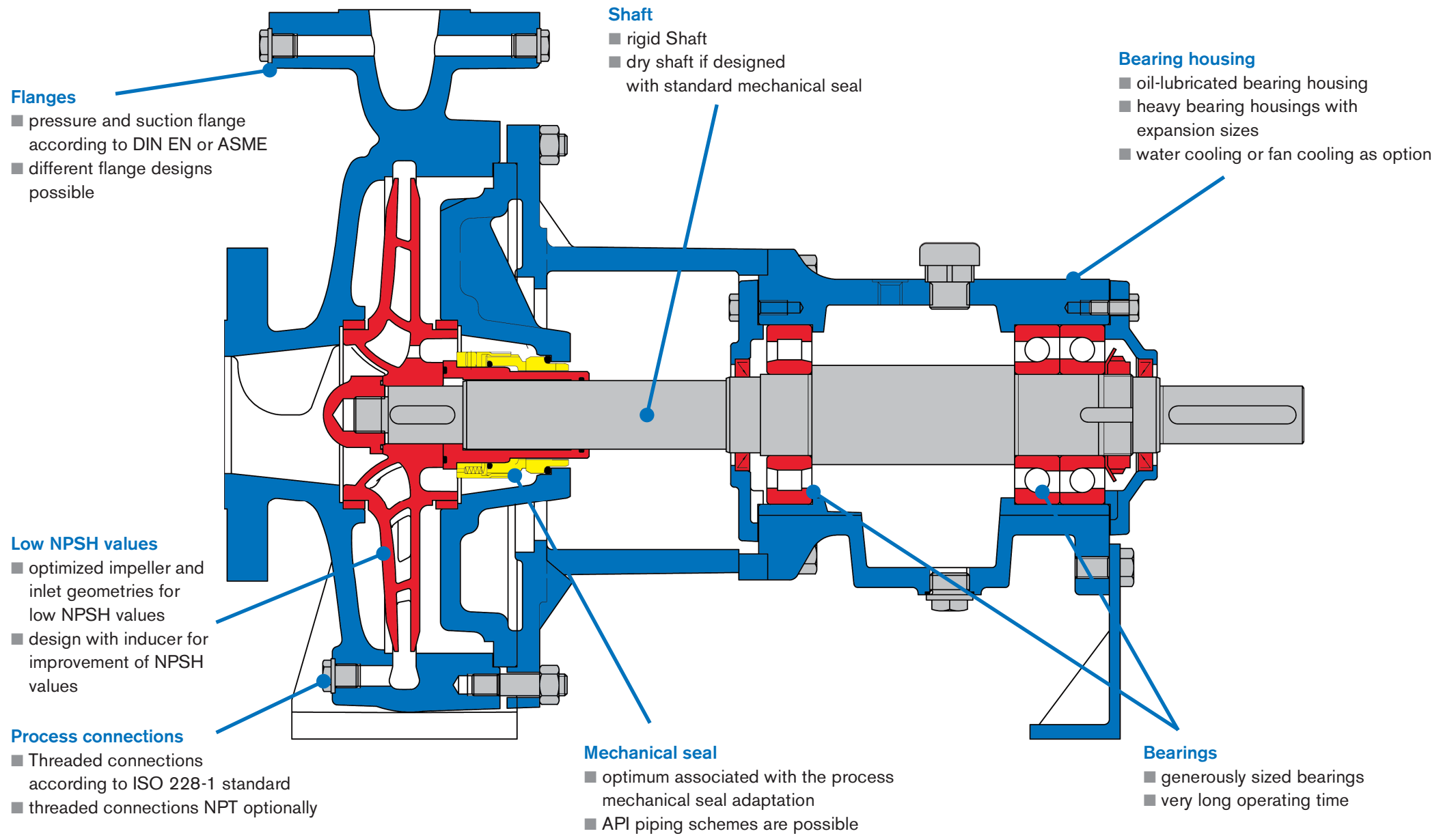

KRCM - with magnetic coupling

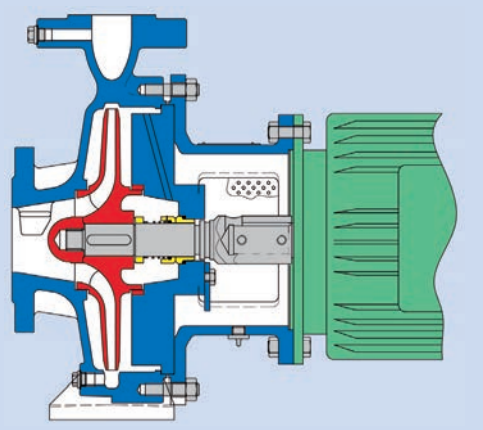

KRCB - block design

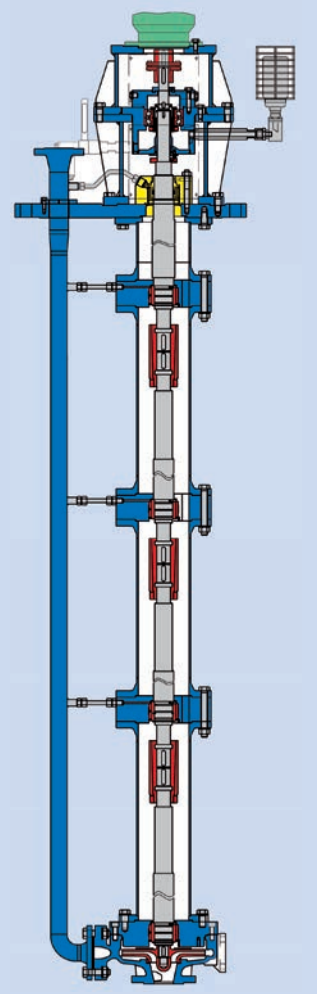

KRCV - vertical design

Performance range

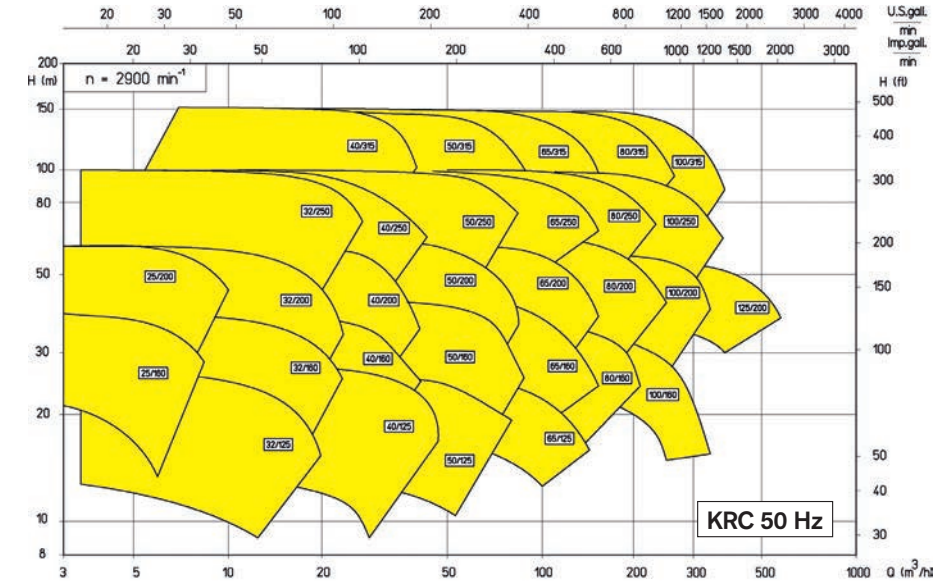
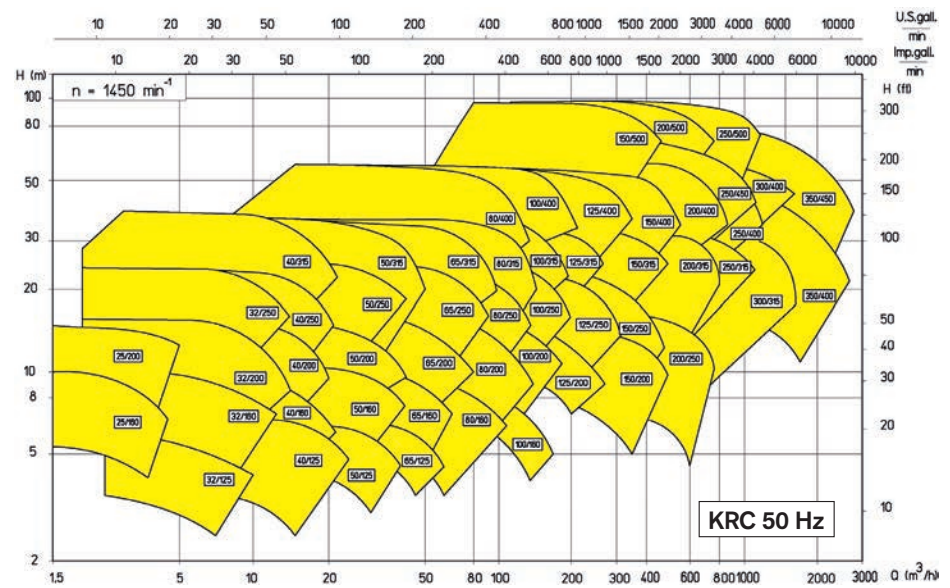

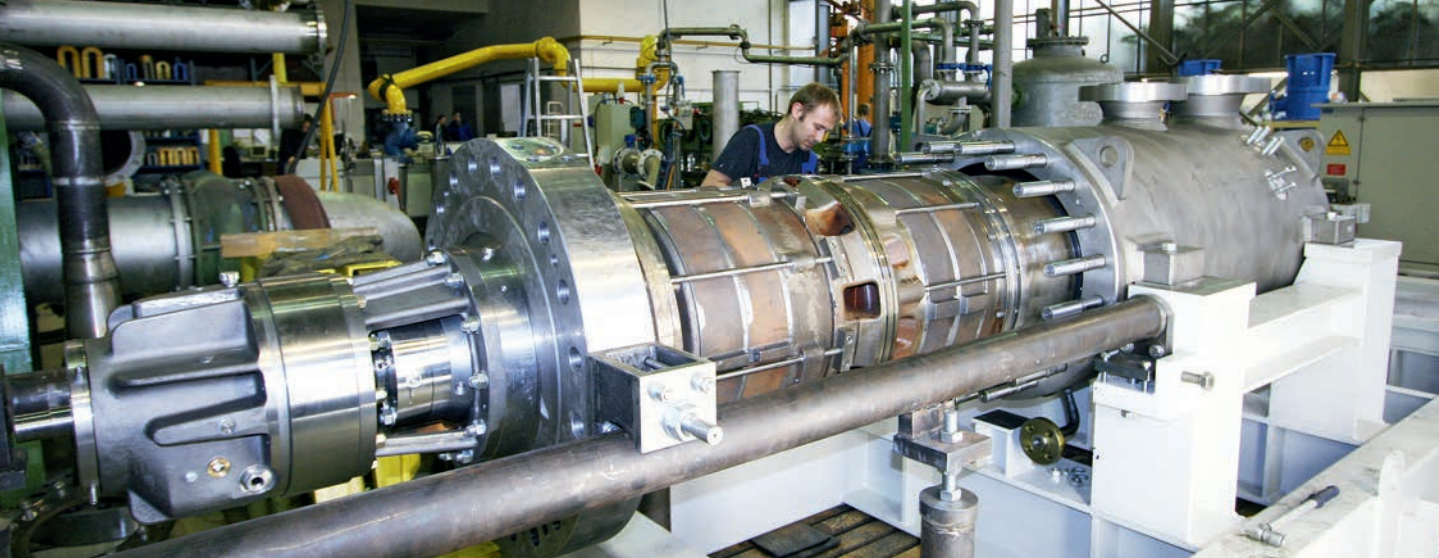

Since more than 100 years APOLLO in Goessnitz has been developing and producing pumps for different applications with most different operating principles.

In continuation of this history Apollo has developed to a Manufacturer of high quality heavy-duty Process Pumps – especially according to API-610 Standard.

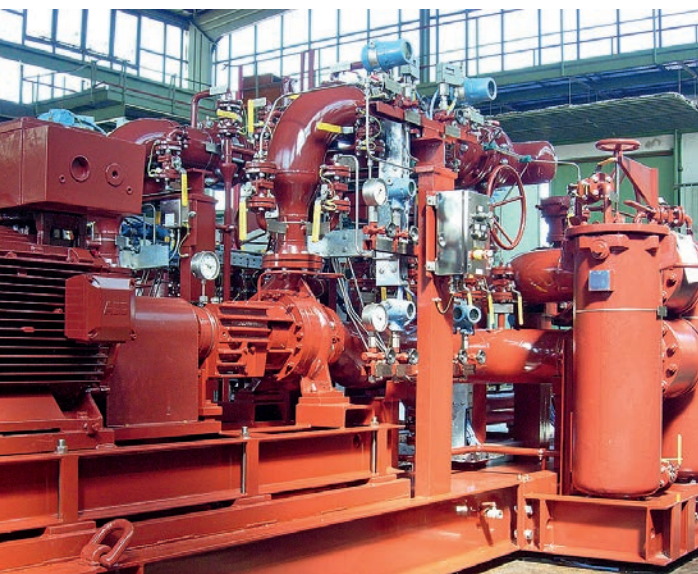

20 years ago, the business Division „System Engineering & System Technology“ was founded. With this division we can offer our Customers complete solutions from a single source. Apollo has high-skilled Personnel for Pumps and Pumping Systems up to Specialists for Electrical and Control Engineering. By taking advantage of these synergies, of short lines of communication, of optimized process

chains and of high Flexibility of our company, we provide our Customers with best support in solving their problems and tasks worldwide.

Our production methods and systems meet the highest level of quality and allow the implementation of orders according to different standards and regulations.

The Quality Assurance in all areas of the company, including suppliers and cooperation partners, is the top priority and is consistently implemented. The most up-to-date test fields provide realistic test conditions.

Today we develop and manufacture with the most modern methods – from the hydraulic design over to 3D CAD design and engineering, FEM calculation to the casting patterns and parts manufacture via CAD-CAM Interfaces.

