

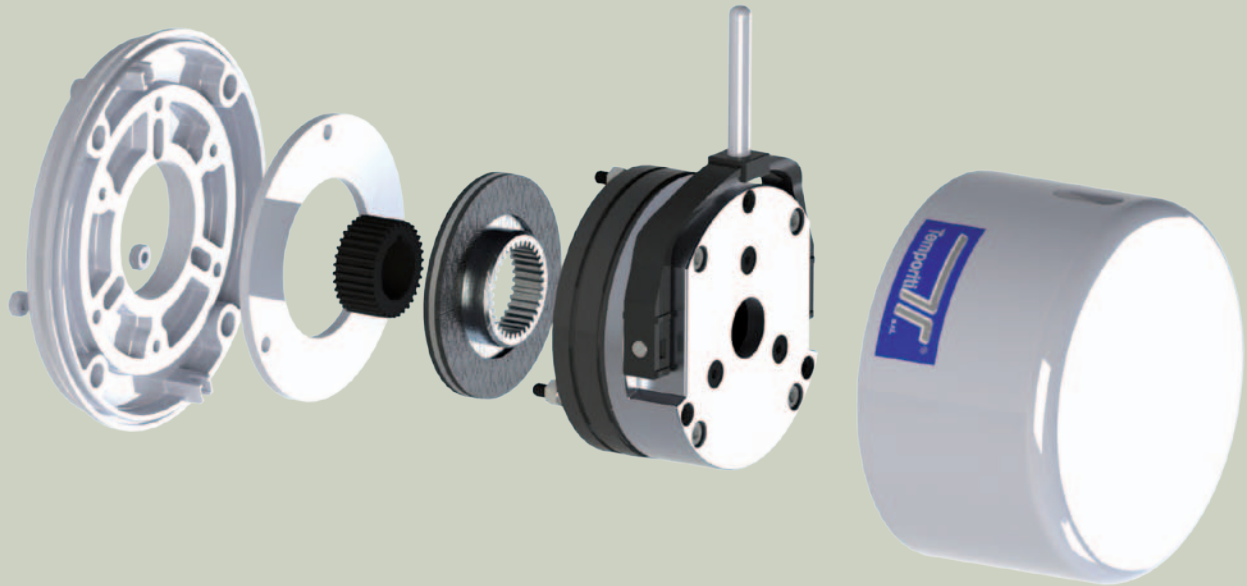

NEMA C-Face spring applied fail-safe brakes



Temporiti® model “K” and “AC” mounted brakes with NEMA 2 housing are designed specifically to interchange with Stearns® and Dings models as shown in Table 1.

Design features of models “K” and “AC” brakes

- Modern and high performance design with extremely durable housing.
- Manufactured with aluminum mounting flange and stamped steel housing, with white zinc plating protection.
- Very quiet in operating (< 70 dBA).
The coil is fully encased in an epoxy resin with IP64 protection.
- Brake enclosure IP57.
- us UL standard, file E210965.
- Zinc plating protects all mechanical parts.
- Hand release system is available upon request.

“K” DC-Powered Brake

- Electromagnet made of forged steel.
- Simple to install and easy to maintain.
- Good heat dissipation due the forged steel construction.

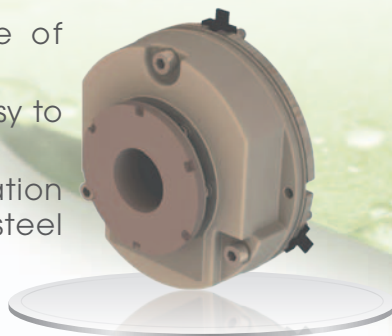

“AC” Three phase Powered Brake

- Easy to assemble and adjust torque settings.
- Aluminum die cast housing allows for good heat dissipation.

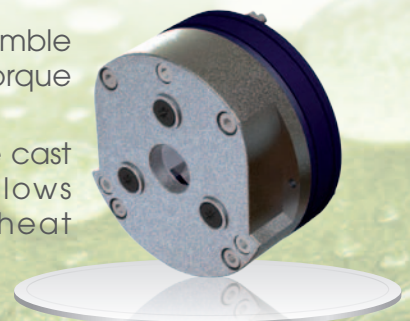

INTERCHANGE PROCEDURE

To interchange a Stearns® or Dings brake with a **Temporiti®** brake, we require the following information, or contact **Temporiti®** for a complete interchange guide.

1. Existing Stearns® and Dings brake type and model number.
2. Hub bore size and keyway dimensions.
3. Required brake voltage, or available power, if brake is not mounted on a motor.
4. Any additional application information and mounting requirements.
5. **Temporiti®** use the same Stearns® and Dings LETTER CODE for the hub and voltage identification.

Note: For installation on the back of a TEFC motor, remove fan and measure the shaft diameter and keyway dimensions, for where the **Temporiti** brake will be mounted.

Stearns® Brake series 56.000 – 56.100 – 56.200 – 56.300 – 56.400 – 56.500-87.000. Dings Brake series 56-60.

Nominal Static torque lb-ft (Nm)	Number of friction disc	Adapter NEMA frame size	AK Dimeter	Temporiti® Brake enclosure	Stearns® AC Brake Model	Dings 5600 End Mount	Temporiti® AC brake Model (for dc brake same code with "K" instead "AC")
1,5 (2)	1	42-48C	3 in. (76,2mm)	IP56 Stearns® (1=IP23)(2=IP54) (3=IP55)	1-048-151-00-xxx* 1-048-151-01-xxx* 1-048-161-00-xxx* 1-048-161-01-xxx*	2-51001-050	56-3-AC3-xxx*
3-6 (4-8)	1	42-48C	3 in. (76,2mm)	IP56 Stearns® (1=IP23)(2=IP54) (3=IP55)	1-048-171-00-xxx* 1-048-171-01-xxx*	2-51003-050 2-51006-050	56-3-AC3-xxx*
1,5 (2)	1	56C	4,5 in. (114,3mm)	IP56 Stearns® (1=IP23)(2=IP54) (3=IP55) Dings (2-4-6)	1-056-00(1-2-4)-00-xxx* 1-056-10(1-2-4)-00-xxx* 1-056-30(1-2-4)-00-xxx*	2-61001-524-xxx** 4-61001-530-xxx** 6-61001-535-xxx** 6-61001-5140-xxx** 6-61001-5116-xxx**	56-4.5-AC3-xxx*(**)
3 (4)	1	56C	4,5 in. (114,3mm)	IP56 Stearns® (1=IP23) (2=IP54) (3=IP55) Dings (2-4-6)	1-056-01(1-2-4)-00-xxx* 1-056-11(1-2-4)-00-xxx* 1-056-21(1-2-4)-00-xxx* 1-056-31(1-2-4)-00-xxx* 1-056-41(1-2-4)-00-xxx*	2-61003-524-xxx** 4-61003-530-xxx** 6-61003-535-xxx** 6-61003-5140-xxx** 6-61003-5116-xxx**	56-4.5-AC3-xxx*(**)
6 (8)	1	56C	4,5 in. (114,3mm)	IP56 Stearns® - (1=IP23) (2=IP54) (3=IP55) Dings (2-4-6)	1-056-02(1-2-4)-00-xxx* 1-056-12(1-2-4)-00-xxx* 1-056-22(1-2-4)-00-xxx* 1-056-32(1-2-4)-00-xxx* 1-056-42(1-2-4)-00-xxx*	2-62006-524-xxx** 4-62006-530-xxx** 6-62006-535-xxx** 6-62006-5140-xxx** 6-62006-5116-xxx**	56-4.5-AC3-xxx*(**)
10 (14)	1	56C	4,5 in. (114,3mm)	IP56 Stearns® (1=IP23)(2=IP54) (3=IP55) Dings (2-4-6)	1-056-03(1-2-4)-00-xxx* 1-056-13(1-2-4)-00-xxx* 1-056-23(1-2-4)-00-xxx* 1-056-33(1-2-4)-00-xxx* 1-056-43(1-2-4)-00-xxx*	2-62010-524-xxx** 4-62010-530-xxx** 6-62010-535-xxx** 6-62010-5140-xxx** 6-62010-5116-xxx**	56-4.5-AC3-xxx*(**)
15 (20)	1	56C	4,5 in. (114,3mm)	IP56 Stearns® (1=IP23)(2=IP54) (3=IP55) Dings (2-4-6)	1-056-04(1-2-4)-00-xxx* 1-056-14(1-2-4)-00-xxx* 1-056-24(1-2-4)-00-xxx* 1-056-34(1-2-4)-00-xxx* 1-056-44(1-2-4)-00-xxx*	2-63015-524-xxx** 4-63015-530-xxx** 6-63015-535-xxx** 6-63015-5140-xxx** 6-63015-5116-xxx**	56-4.5-AC4-xxx*(**)

**Stearns® Brake series 56.000 – 56.100 – 56.200 – 56.300 – 56.400 – 56.500-87.000.
Dings Brake series 56-60.**

Nominal Static torque lb-ft (Nm)	Number of friction disc	Adapter NEMA frame size	AK Dimeter	Temporiti® Brake enclosure	Stearns® AC Brake Model	Dings 5600 End Mount	Temporiti® AC brake Model (for dc brake same code with "K" instead "AC")
20 (27)	2	56C	4,5 in. (114,3mm)	IP56 Stearns® (1=IP23)(2=IP54) (3=IP55) Dings (2-4-6)	1-056-05(1-2-4)-00-xxx* 1-056-15(1-2-4)-00-xxx* 1-056-25(1-2-4)-00-xxx* 1-056-35(1-2-4)-00-xxx* 1-056-45(1-2-4)-00-xxx*	2-63020-524-xxx** 4-63020-530-xxx** 6-63020-535-xxx** 6-63020-5140-xxx** 6-63020-5116-xxx**	56-4.5-AC4/D-xxx*
25 (34)	2	56C	4,5 in. (114,3mm)	IP56 Stearns® (1=IP23)(2=IP54) (3=IP55) Dings (2-4-6)	1-056-06(1-2-4)-00-xxx* 1-056-16(1-2-4)-00-xxx* 1-056-26(1-2-4)-00-xxx* 1-056-36(1-2-4)-00-xxx* 1-056-46(1-2-4)-00-xxx*	2-64025-524-xxx** 4-64025-530-xxx** 6-64025-535-xxx** 6-64025-5140-xxx** 6-64025-5116-xxx**	56-4.5-AC4/D-xxx*
10 (14) 15 (20) 20 (27) 25 (34)	1	182-184TC	8.50 in (215,9mm)	IP56 Stearns® (1=IP23)(2=IP54) (3=IP55) Dings (2-4-6)	1-056-53(1-2-4)-00-xxx* 1-056-54(1-2-4)-00-xxx* 1-056-55(1-2-4)-00-xxx* 1-056-56(1-2-4)-00-xxx*	-	56-8.5-AC5-xxx*
35 (47)	1	182-184TC	8.50 in (215,9mm)	IP56 Stearns® (1=IP23)(2=IP54) (3=IP55)	1-087-04(1-2-4)-00-xxx*	-	56-8.5-AC6-xxx*
50 (68)	1	182-184TC	8.50 in (215,9mm)	IP56 Stearns® (1=IP23)(2=IP54) (3=IP55)	1-087-05(1-2-4)-00-xxx*	-	56-8.5-AC7-xxx*
75 (102)	1	182-184TC	8.50 in (215,9mm)	IP56 Stearns® (1=IP23)(2=IP54) (3=IP55)	1-087-06(1-2-4)-00-xxx*	-	56-8.5-AC7-xxx*
105 (147)	2	182-484TC	8.50 in (215,9mm)	IP56 Stearns® (1=IP23)(2=IP54) (3=IP55)	1-087-08(1-2-4)-00-xxx*	-	56-8.5-AC7D-xxx*

*XXX= HUB AND VOLTAGE SELECTION CODE ARE THE SAME LIKE Stearns®

**XXX= HUB AND VOLTAGE SELECTION CODE ARE THE SAME LIKE Dings

LEADWIRE POSITION CAN BE INTERNAL OR EXTERNAL JUST POSITIONING THE BRAKE CABLES.

Warning! Before selecting an adapter to mount a brake on a larger motor frame, the torque and heat dissipation required by the application should be determined. A larger motor may indicate a requirement for greater thermal capacity than the brake is designed for. The brake selection must be matched to the motor and application requirement, which we invite to visit the web site www.temporiti.it for all technical specification, limit of working, safety, maintenance. Brake torque value is always set with the max value. For adjusting see on www.temporiti.it.

Standard ADPTER NEMA

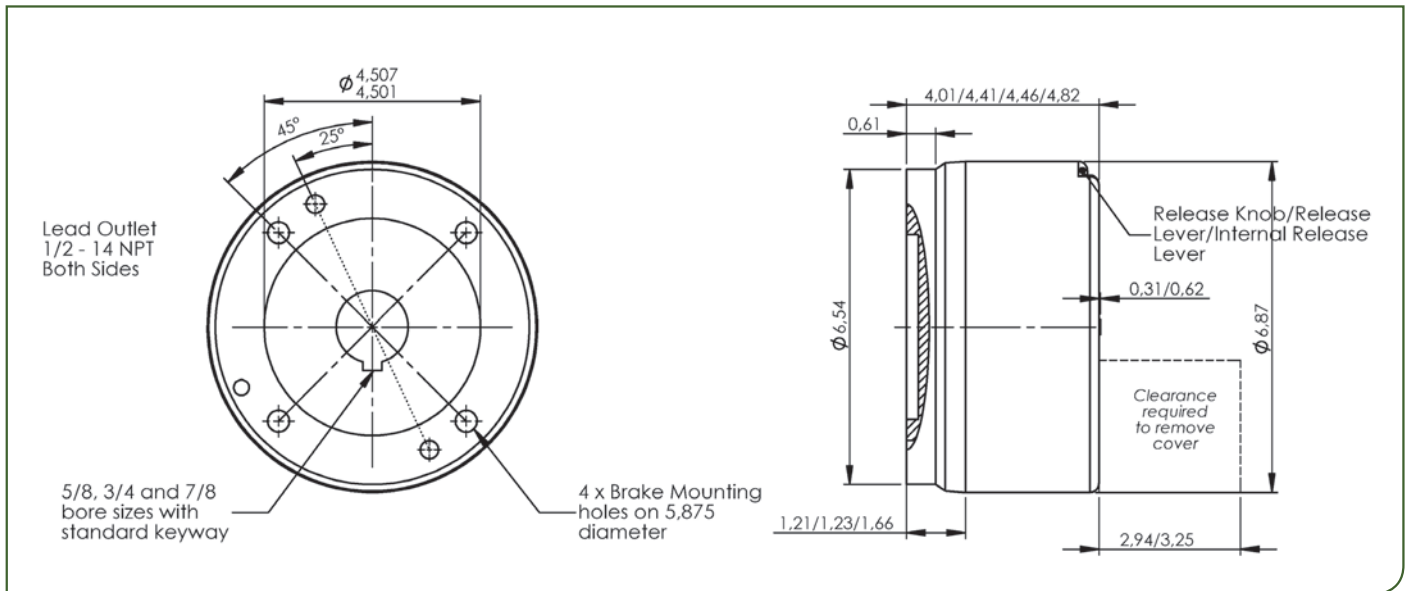

Temporiti® ADPTER NEMA

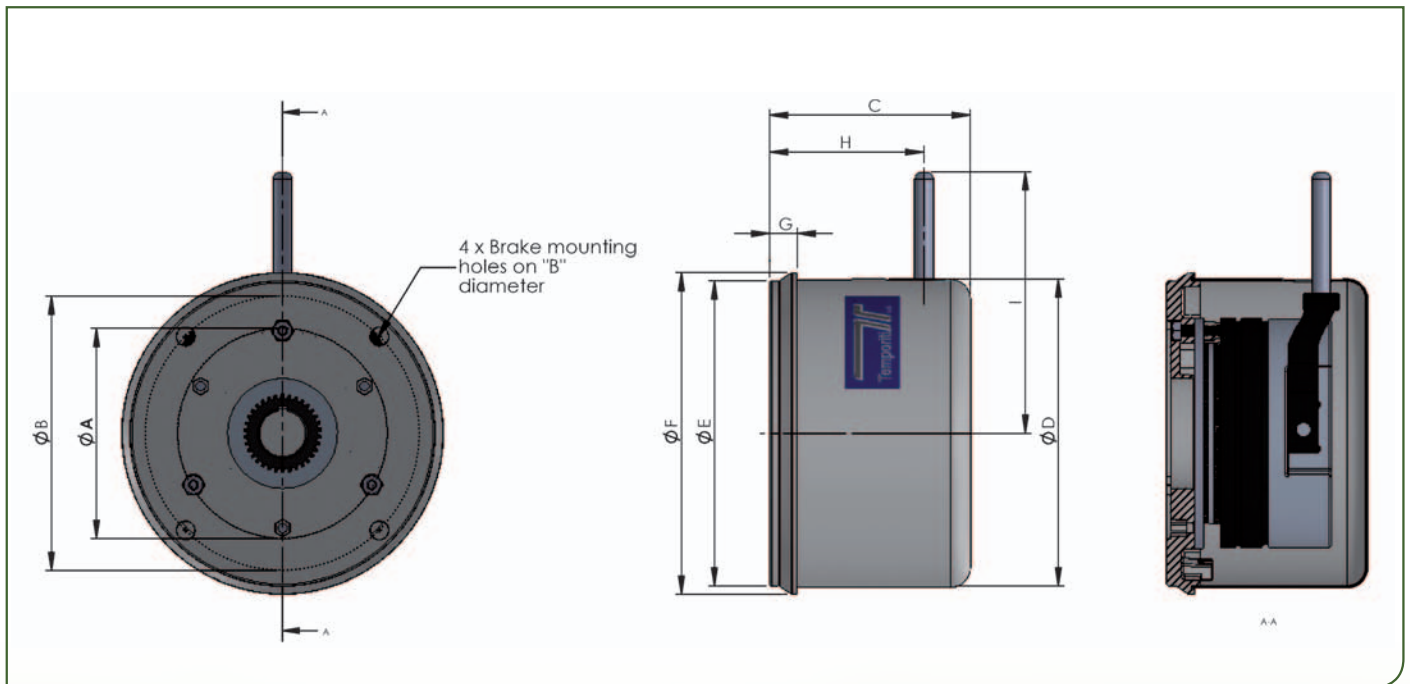

Dimensions (inch)

ADAPTER NEMA FRAME SIZE	A	B	C	D	E	F	G	H*	I*
42 - 48C	3,0	3,750	3,307	5,689	5,591	5,787	0,354	2,20	3,70
56C	4,5	5,875	4,300	6,570	6,540	6,890	0,590	3,31	5,60
182 - 184TC	8,5	7,250	5,108	9,173	9,055	9,449	0,591	6,25	10,50

* Values are approximate

ORDERING AND IDENTIFICATION INFORMATION

The following tables show the hub and voltage selection which you must indicate the value with your order.

Stearns® HUB CODE REFERENCE

Hub Type	Bore (in.)	Keyway** (in. x in.)
A*	5/8	1/8 X 1/16
B	5/8	3/16 X 3/32
C	3/4	3/16 X 3/32
D	7/8	3/16 X 3/32
E	1-1/8	1/4 X 1/8
F*	1-1/4	1/4 X 1/8
K	1/2	1/8 X 1/16
L*	1	1/4 X 1/8
N*	9/16	1/8 X 1/16
O*	11/16	3/16 X 3/32
P*	1-1/16	1/4 X 1/8
R*	13/16	3/16 X 3/32
S*	15/16	1/4 X 1/8

Dings HUB CODE REFERENCE

Hub Type	Bore (in.)	Keyway** (in. x in.)
D	5/8"	3/16" X 3/32"
E	3/4"	3/16" X 3/32"
F	7/8"	3/16" X 3/32"

*These bores are non-standard - ** Keyways set made to ANSI B17.1 standard.

AC brake connection

(three phase):

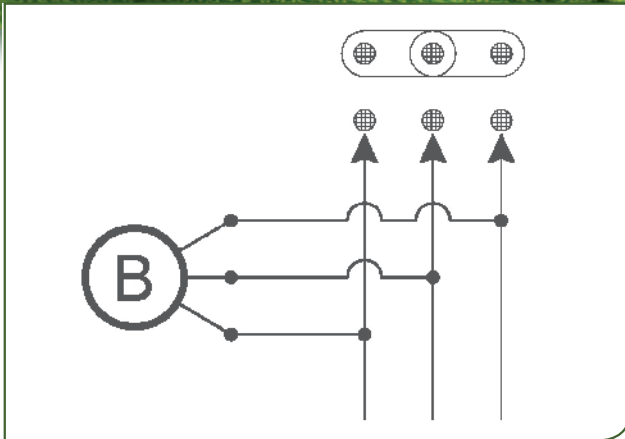

DC brake connection

(half or full rectifier is needed):

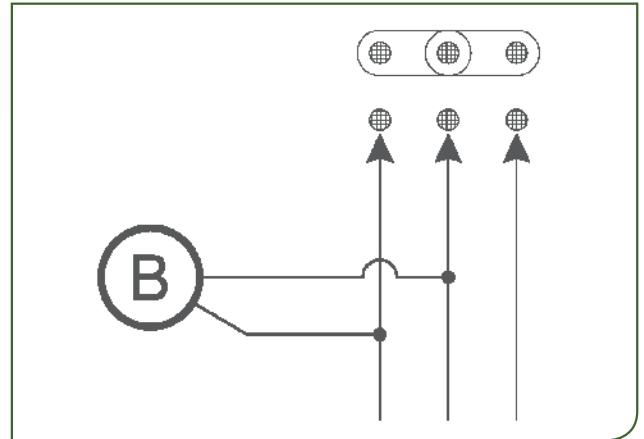

Stearns® VOLTAGE CODE REFERENCE

TYPE	Standard AC Voltage Rating	Hz
B	115	60
C	110	50
E	200	60
F	230 190	60 50
H	220	50
L	460 380	60 50
M	415	50
N	575	60
O	110/220	50
P	115-208/230	60
Q	208-230/460 190/380	60 50
R	230/400	60

TYPE	Standard DC Voltage Rating
T	12
U	24
V	36
W	48
X	95
Y	115
Z	230

Dings VOLTAGE CODE REFERENCE

TYPE	Standard AC Voltage Rating	Hz
P	575	60
R	115/230	60
T	220/440	60
U	230/460	60
Y	110/220	50
1	115/230	60
5	208/460	60



Via E. Mattei, 8
20010 Mesero (MI) - Italy

Ph. 0039-029787331
Fax 0039-0297289574

info@temporiti.it
www.temporiti.it



The new @Temporiti_srl #C_Flange is arrived: follow us!